

TRONCHETTI IN ACCIAIO INOX

Realizzati nel nostro stabilimento con l'uso esclusivo di tubi in acciaio inox AISI 304L, certificati ed omologati.

Lavorazione e filettatura eseguita con uso di macchine automatiche CNC.

INOX STEEL TRUNKS

Made in our factory with the exclusive use of inox steel tubes AISI 304L, certified and approved.

Processing and threading worked with CNC automatic machines.

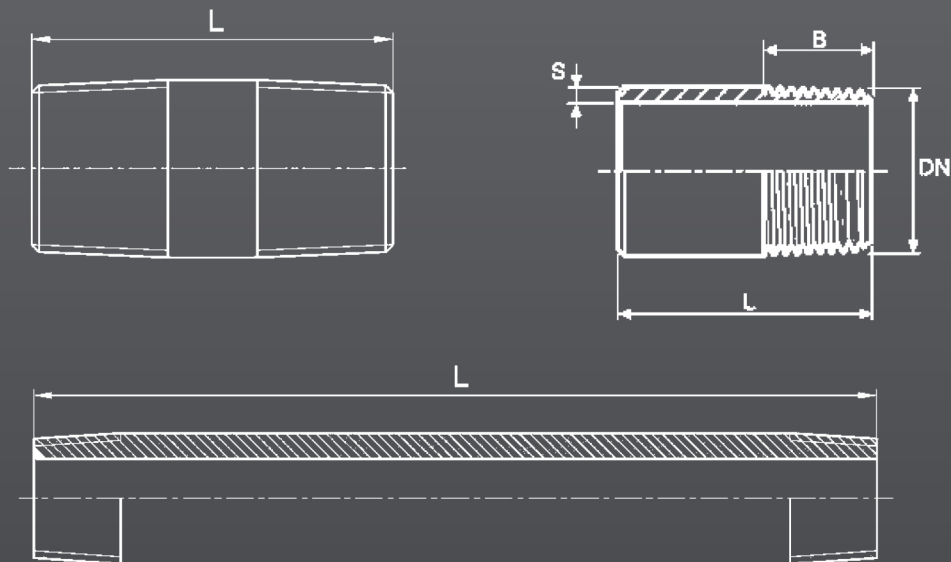

Tabella Tecnica
Technical Table

Codice	Diametro nominale (mm)	Filettatura (mm)	Diametro Esterno (mm)	Lunghezza (mm)	Lunghezza* Filettatura (mm)	Spessore** (mm)
Type	Nominal diameter (mm)	Thread (inch)	Outside diameter (mm)	Length (mm)	Thread* Length (mm)	Thickness** (mm)
	DN		Ø	Min - Max	B	S
530X - 650X	8	1/4	13,7	40-3000	12	2,0
	10	3/8	17,2	40-3000	12	2,0
	15	1/2	21,3	40-3000	16	3,0
	20	3/4	26,9	40-3000	16	3,0
	25	1"	33,7	40-3000	18	3,0
	32	1"1/4	42,4	50-3000	19	3,0
	40	1"1/2	48,3	50-3000	21	3,0
	50	2"	60,3	50-3000	25	3,0
	65	2"1/2	76,1	100-3000	28	4,0
	80	3"	88,9	100-3000	30	4,0
	100	4"	114,3	100-3000	33	4,0
	125	5"	139,7	150-300	34	4,0

*Tolleranza come da Normativa EN 10266

*Tolerance as per Standard EN 10266